

3DO, the 3DO logos and Interactive Multiplayer are trademarks of The 3DO Company.

SHADOW

WAR OF SUCCESSION



SHADOW; War Of Succession is a registered trademark of Tribeca Digital Studios. Software © 1994 Tribeca Digital Studios, Inc.

CONTENTS

Introduction.....3

Setting Up.....4

Game Rules.....5

Choosing A Character.....6

Game Screen.....7

Controls.....8

Who Will Be The Next Shadow King ?

Anvil Stiles..... 11

Erika Storm..... 12

Carlos Cortez..... 13

Riggs Riddick..... 14

Sasha Romanoff..... 15

Gabriella St. John..... 16

Viper..... 17

Credits..... 18

INTRODUCTION

It is the near future and the head of the world's largest criminal network, S.H.A.D.O.W. (Syndicate of Hate, Anarchy, Destruction, and Organized Warfare), has just been murdered by an unknown assassin.

The Shadow King's death has created a power vacuum within S.H.A.D.O.W. A vacuum which has to be filled immediately.

From around the world seven of the Shadow King's best lieutenants and confidants from different branches of his vast criminal empire have come to do battle.

Among these Shadow warriors, to the winner goes the ultimate prize, the right to be named the next Shadow King.

To the losers, there is only death.

Who will be the next Shadow King ?

1. Plug in your controller into the control port. If you are using two controllers, plug the second controller into the first one.
2. Turn the Power Switch to ON on your 3DO player.
3. Press the Open/Close Button to open CD Drawer.
4. Place the CD into the Drawer, label side up.
5. Press the Open/Close Button to close the drawer.
6. Press the Play button on your 3DO controller and let **THE BATTLES BEGIN !**

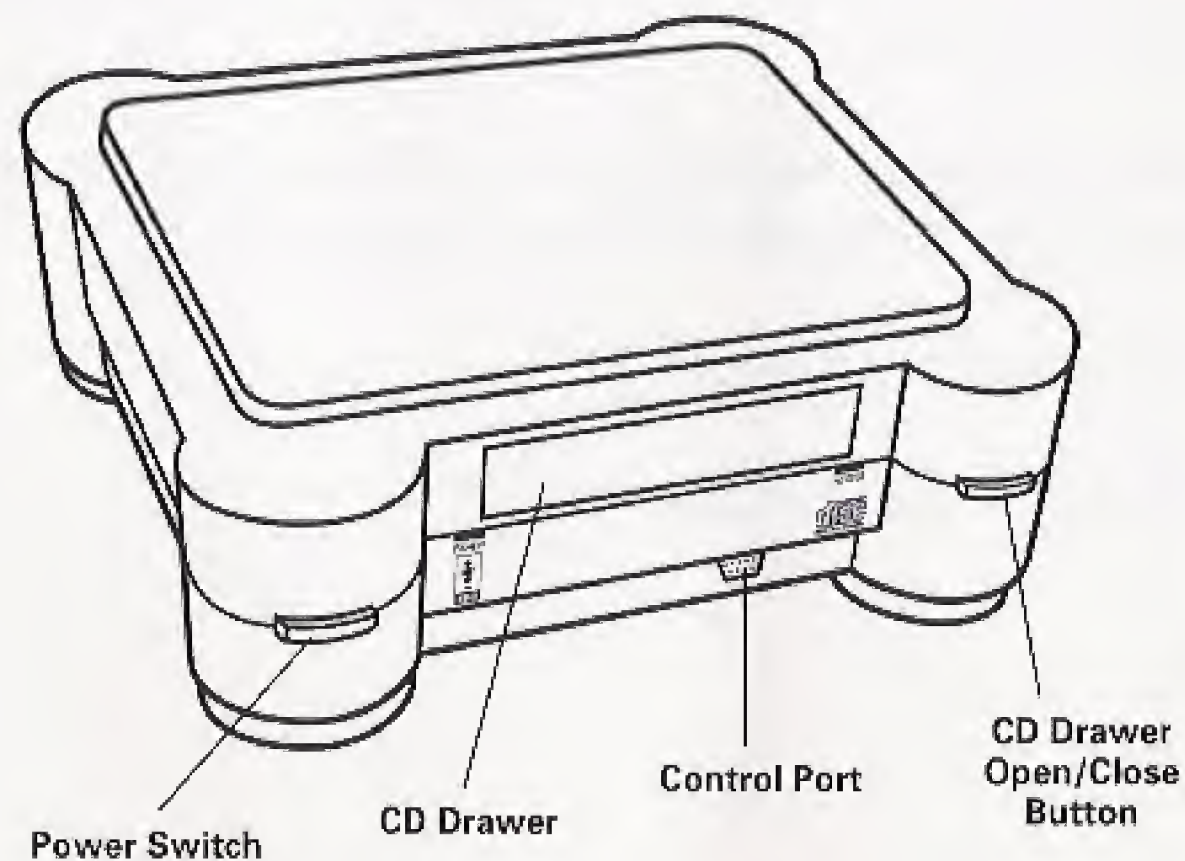

Each Shadow fighter will try to win two of three rounds per contest.

If a tie ensues after the time has expired, an extra round will be given to break the tie.

In a one player game, the computer will always randomly select your opponents.

In one player mode, you are given three chances to continue after you have been defeated.

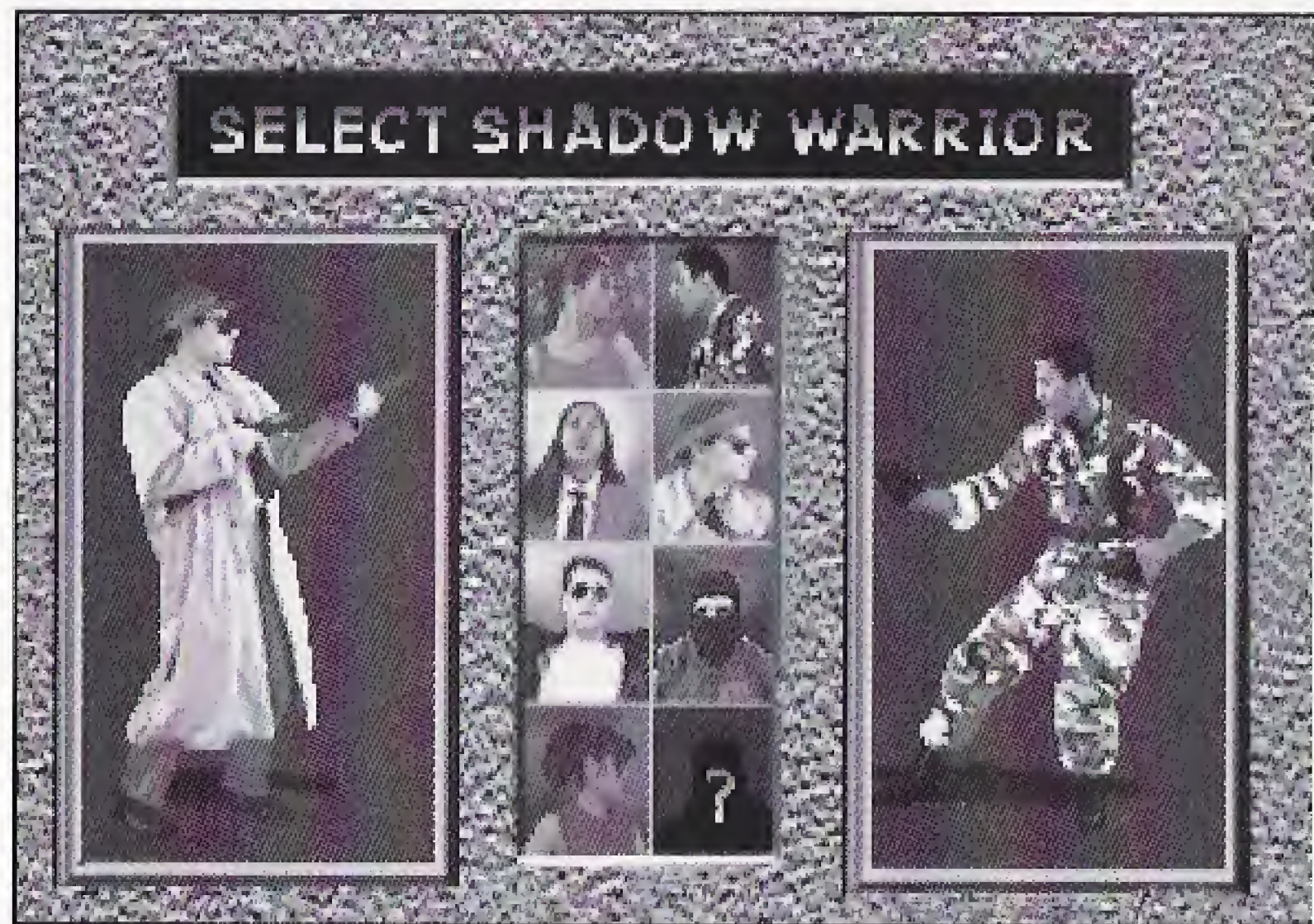

You can choose a Shadow warrior by scrolling through each one of them using the game controller. Once you have made your choice, press the "A" button and let the battle begin!



Above the two Shadow fighters are their respective life meters and scores. In between the two life meters is the time remaining for the round.

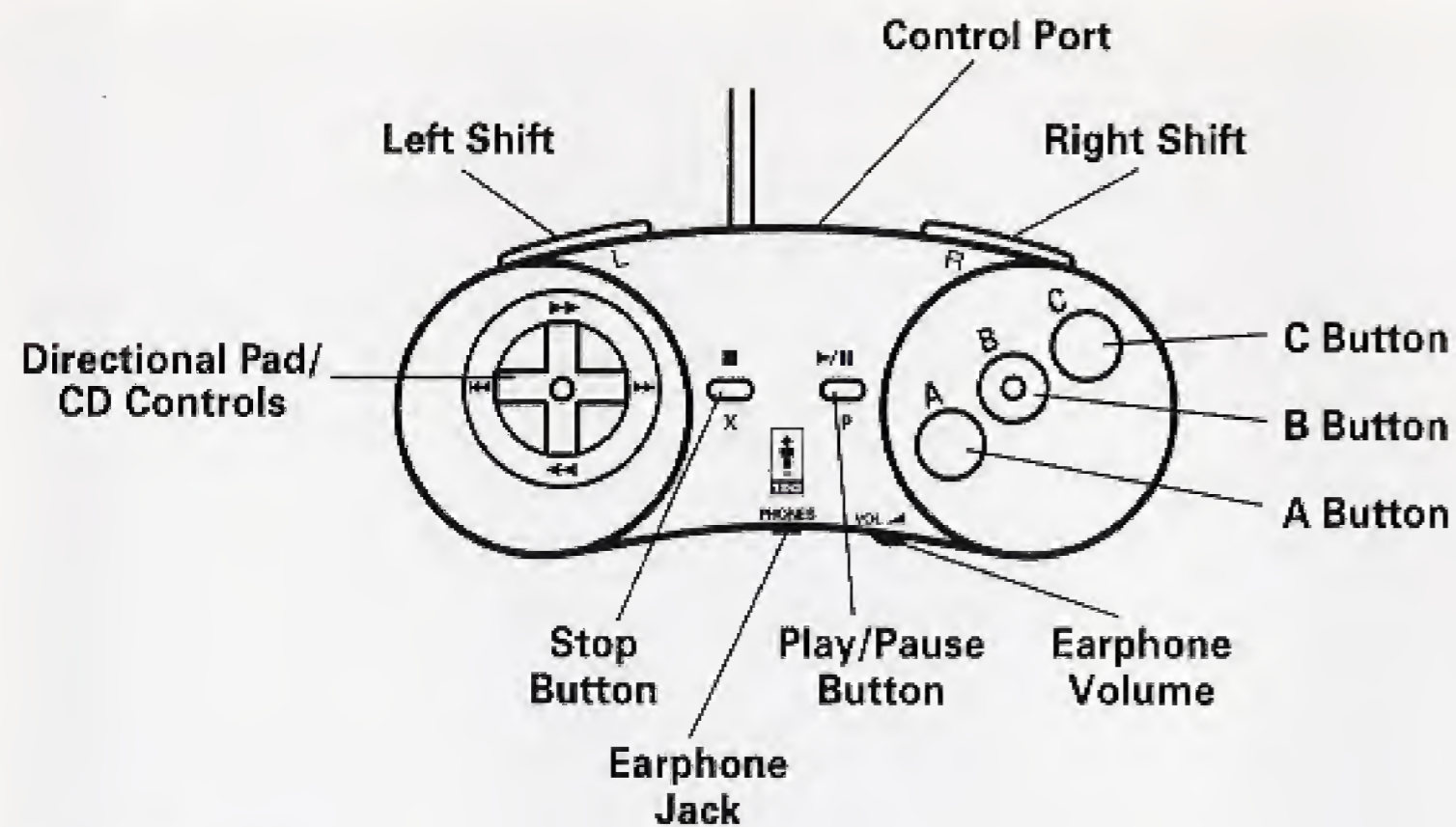

Basic Moves

- Directional Pad.....Movement
- A Button.....Punch
- B Button.....Kick
- Right Shift.....Block
- Jump + Punch..... Flying punch
- Jump + Kick..... Flying kick

Higher Level Moves

- Toward + Punch..... Strong punch
- Toward + Kick..... Strong kick
- Away + Kick..... Foot sweep
- Down + Punch..... Uppercut

Crouch Moves

- Down.....Crouch
- Down + Kick.....Crouch kick
- Down + Block.....Crouch block

Close Quarters Combat (If opponent is very close)

- B Button.....Knee
- Away + Punch.....Throw

Special Moves

See character descriptions.

WHO WILL BE THE NEXT SHADOW KING ?



Stiles is regarded by his fellow S.E.A.L. Team members as the best. Stiles was an unarmed combat instructor at the NAVY's UDT school. He joined the contest after the disappearance of his younger brother who worked for S.H.A.D.O.W. By beating all the other combatants, Stiles hopes to gain access to the Shadow King's files and shed light on the fate of his brother.

Weapons/Powers: Knife

Special Moves/Abilities:

Stiles' Slide

Trips up an opponent.

(Toward + Toward + C)

Knife Throw

Deadly if done right.

(Down + Toward + A)



Erika Storm has been groomed from birth to one day take over her father's empire. As a result of this, she has had the best training money could buy. With the death of her father whom she loved dearly, Erika has made it her goal to avenge his death and claim her birthright as the head of S.H.A.D.O.W. Her preferred killing weapon is the katana.

Weapons/Power: Katana

Special Moves/Abilities:

Katana Blast

A blast of power gushes out from the tip of her sword.

(Away + Toward + C)

Disappear

Erika vanishes.

(Away + Toward + Right Shift)



Carlos has been working undercover for the F.B.I. for the last three years. His work has been so good that he has penetrated the deepest areas of S.H.A.D.O.W.'s illegal activities. However, there have been a number of disturbing F.B.I. dispatches which report that Cortez has been personally and actively participating in assassinations and executions of S.H.A.D.O.W.'s enemies. These reports have the F.B.I. confused. Is Carlos Cortez still a federal agent doing his job or, has he turned into one of the Shadow King's pawns ?

Weapons/Power: Shotgun

Special Moves/Abilities:

Flash Bomb

Carlos disappears with the help of F.B.I. issue smoke bombs.

(Away + Toward + C)

Shotgun Fire

Carlos blasts an opponent with hot lead.

(Toward + Toward + C)



Riggs Riddick was the head drug dealer for the Shadow King. Unfortunately, Riddick got greedy and began skimming off the top. When the Shadow King found out, he had Riggs executed by Carlos Cortez. Before he died, though, the devil appeared before Riddick and made a deal with him. He would get a second chance at life in the form of the Pale Rider provided that the devil would get all the souls which the Pale Rider killed. Since then, the Pale Rider has devoted his ghostly existence to the death of the Shadow King.

Weapons/Powers: Hellish Power
Special Moves/Abilities:

Hellfire

Hurls hellish fire towards an opponent.

(Away + Toward + A)

Riggs Roll

Riggs curls up into a ball and smashes into an opponent.

(Toward + Down + Away)



Trained as a Russian agent, Sasha decided that she was never going to be rich and powerful if she continued working for the government. As a result, she "quit" the Agency and joined the ranks of S.H.A.D.O.W. With the death of the Shadow King, Sasha has a golden opportunity to have it all at last.

Weapons/Powers: Dagger
Special Moves/Abilities:

Stealth

Makes her disappear during battle.

(Away + Down + C)

Dagger Draw

Hurls multiple daggers at opponent.

(Down + Toward + A)



Gabriella St. John is the best bodyguard money can buy. She has never failed an assignment in her life. Until now. With the death of the Shadow King, (which happened outside her shift) Gabriella's reputation has been tarnished. As a final act of atonement for her failure, Gabriella has joined the battle to avenge the death of her employer.

Weapons/Powers: Hand to Hand

Special Moves/Abilities:

Mesmerize

Hypnotizes an opponent.

(Toward + Toward +
Away + Away)

Cannonball

Hurls towards an opponent.

(Toward + Down + Away)



Not much is known about Viper. Nothing is clear about him except the fact that he always shows up at S.H.A.D.O.W. 's illegal activities and puts a stop to them. Theories about him abound. Some say he is a masked vigilante while others claim he is the angel of Death incarnated in human form. Sources say that Viper possesses incredible powers which allow him to do superhuman acts. Of course, these reports have not been confirmed. His motive for joining the contest is as mysterious as the man himself.

Weapons/Power: Unknown

Special Moves/Abilities:

Unknown

Executive Producer	Lawrence Ng
Producer	Tong Manalac
Programmer	Mark Erdtmann
Lead Artist	Alvin Williamson
Script/Manual	Joel Manalac
Script/Talent	R.J. Araneta
Photography/Background Art	I/O 360 Arkadiusz Banasik Nam Szeto Dindo Magallanes
Additional Art	Jenny Woo
Music/Sound	Rob Wallace
Actors	Denise Soohoo Anthony Filipakis Jennifer Polintan Donna Roque
Voices	Rob Wallace

Special thanks to Carrie Holder

1. THE 3DO COMPANY SHALL NOT BE LIABLE TO THE END USER FOR ANY LOSS OF DATA, LOST PROFITS, COST OF SUBSTITUTE GOODS OR OTHER CONSEQUENTIAL, INCIDENTAL, SPECIAL, PUNITIVE OR INDIRECT DAMAGE ARISING OUT OF THE USE OF THE SOFTWARE.

2. THE 3DO COMPANY MAKES NO WARRANTIES, EXPRESS, IMPLIED OR STATUTORY, REGARDING THE SOFTWARE, INCLUDING, WITHOUT LIMITATION THE IMPLIED WARRANTIES MERCHANTABILITY AND FITNESS FOR ANY PARTICULAR PURPOSE, OR ANY EQUIVALENT UNDER THE LAWS OF JURISDICTION.

3. DO NOT USE A FRONT OR REAR PROJECTION TELEVISION WITH THIS PRODUCT. YOUR PROJECTION TELEVISION SCREEN MAY BE PERMANENTLY DAMAGED IF STATIONARY SCREENS OR PATTERNS ARE PLAYED ON YOUR PROJECTION TELEVISION. SIMILAR DAMAGE MAY OCCUR IF YOU PLACE THIS PRODUCT ON HOLD OR PAUSE. IF YOU USE YOUR PROJECTION TELEVISION WITH THIS PRODUCT, NEITHER THE 3DO COMPANY NOR TRIBECA DIGITAL STUDIOS, INC. WILL BE LIABLE FOR ANY RESULTING DAMAGE. THIS SITUATION IS NOT CAUSED BY A DEFECT IN THIS PRODUCT OR THE 3DO SYSTEM; OTHER FIXED OR REPETITIVE IMAGES MAY CAUSE SIMILAR DAMAGE TO A PROJECTION TELEVISION. PLEASE CONTACT YOUR TV MANUFACTURER FOR FURTHER INFORMATION.

4. THE EXECUTION OF SOFTWARE WITH THE 3DO SYSTEM INVOLVES THE USE OF PATENT RIGHTS, GRANTED OR APPLIED FOR, IN CERTAIN COUNTRIES. A PURCHASER OF THE 3DO SYSTEM IS LICENSED TO USE SUCH PATENT RIGHTS WITH SOFTWARE LICENSED BY THE 3DO COMPANY. NO LICENSE, IMPLIED OR OTHERWISE, IS GRANTED FOR THE EXECUTION OF OTHER SOFTWARE.

EPILEPSY WARNING

A VERY SMALL PERCENTAGE OF PEOPLE MAY EXPERIENCE EPILEPTIC SEIZURES WHEN EXPOSED TO CERTAIN LIGHT PATTERNS OR FLASHING LIGHTS, INCLUDING THOSE THAT APPEAR ON A TV SCREEN AND WHILE PLAYING VIDEO GAMES. IF YOU, OR ANYONE IN YOUR FAMILY, HAS AN EPILEPTIC CONDITION, CONSULT YOUR PHYSICIAN PRIOR TO PLAYING. IF YOU EXPERIENCE ANY OF THE FOLLOWING SYMPTOMS WHILE PLAYING A VIDEO GAME-DIZZINESS, ALTERED VISION, EYE OR MUSCLE TWITCHES, DISORIENTATION, LOSS OF AWARENESS, ANY INVOLUNTARY MOVEMENT OR CONVULSIONS-IMMEDIATELY DISCONTINUE USE AND CONSULT YOUR PHYSICIAN BEFORE RESUMING PLAY.

COPYRIGHT NOTICE

THIS MANUAL, AND ALL THE SOFTWARE DESCRIBED IN THIS MANUAL, ARE COPYRIGHTED. ALL RIGHTS ARE RESERVED BY TRIBECA DIGITAL STUDIOS, INC. NO PART OF THIS MANUAL OR THE DESCRIBED SOFTWARE MAY BE REPRODUCED, COPIED, TRANSLATED, OR REDUCED TO ANY ELECTRONIC MEDIUM OR MACHINE-READABLE FORM WITHOUT THE PRIOR WRITTEN CONSENT OF TRIBECA DIGITAL STUDIOS, INC.